

Name:

TIE Sentinel

Type: Sienar Fleet Systems TIE/sn Sentinel Scout

Scale: Starfighter

Length: 8.2 Meters

Skill: Starfighter Piloting - TIE

Crew: 2

Crew Skill: Starfighter Piloting 5D, Starship

Gunnery 3D+2

Consumables: 2 Days

Cargo Capacity: 55 Kg

Hyperdrive Multiplier: No

Hyperdrive Backup: No

Nav Computer: N/A

Space: 8

Atmosphere: 350;950kmh

Maneuverability: 2D

Hull: 3D

Shields: None

Sensors:

Passive: 35/1D

Scan: 60/2D

Search: 80/3D

Focus: 2/4D+1

Weapons:

Heavy Laser Cannon

Fire Arc: Turret

Fire Control: 1D

Space: 1-3/12/25

Atmosphere Range: 100-300/1.2/2.5km

Damage: 4D

Twin Heavy Laser Cannons (Fire Linked)

Fire Arc: Front

Fire Control: 3D

Space: 1-3/12/25

Atmosphere Range: 100-300/1.2/2.5km

Damage: 5D

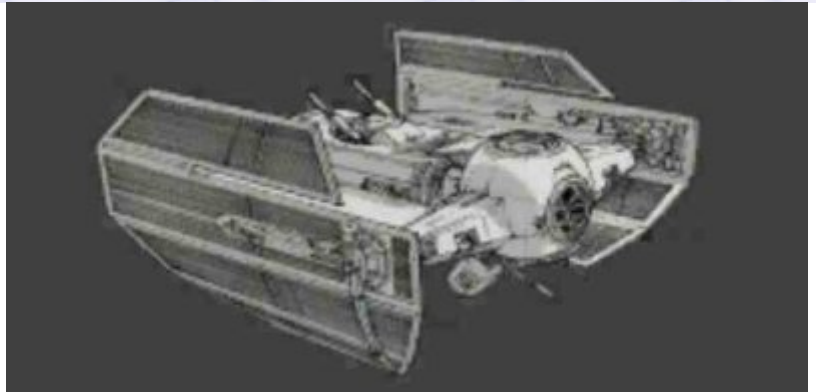

Description: The TIE Sentinel is a scout and patrol ship from the early days of the Galactic Empire. This fighter, although not a great improvement over the standard TIE, is a two man patrol vessel with improved range, sensors and weapons. Designed to scout out enemy fleets for attack by Star Destroyers and other capital ships, the Sentinel was labelled "The Emperors Eyes", but slowly found itself sidelined as normal TIE's were used for its role. Sentinels continued to be used for a while as gunships, the two man crew controlling the two turrets mounted on the fighter, the heavy twin turret on the fighters spine usually controlled by the second crew member, and the single laser cannon mounted on its belly usually controlled by the pilot. Sentinels remain in use on the fringe of Imperial Territory, where their flexibility remains a large advantage, but most of these vessels have been retired and they are rarely seen in operation.

---

Page designed in Notepad, logo`s done on Personal Paint on the Amiga.

Text completely by FreddyB. Image is from Star Wars: Galaxies: Jump to Lightspeed, copyright remains with Sony InterActive / LucasArts.

Any complaints, writs for copyright abuse, etc should be addressed to the Webmaster [FreddyB.](#)